

P2755, P2756, P2757

RACEWAY HANGERS

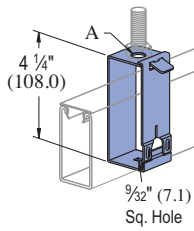

Design Load  
120 Lbs (0.53 kN)

Part No.	"A" In (mm)	Wt/100 pcs Lbs (kg)
P2755	9/16 14.3	44 20.0
P2756	7/8 22.2	44 20.0
P2757	13/32 10.3	44 20.0

Use with Channels:  
P1001, P1101, P2001,  
P5000, & P5500.  
Material: 14 gauge (1.9).

P2855, P2856, P2857

RACEWAY HANGERS

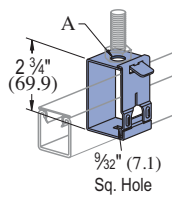

Design Load  
120 Lbs (0.53 kN)

Part No.	"A" In (mm)	Wt/100 pcs Lbs (kg)
P2855	9/16 14.3	32 14.5
P2856	7/8 22.2	32 14.5
P2857	13/32 10.3	32 14.5

Use with Channels:  
P1000, P1100,  
P3000, P3300  
Material: 14 gauge (1.9).

P2537, P5537

FLUORESCENT FIXTURE HANGERS

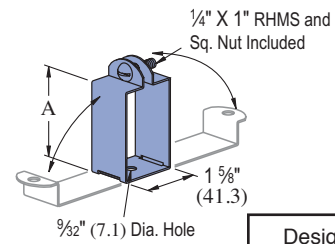

Design Load  
120 Lbs (0.53 kN)

• Hanger provides more than 1/2" (12.7) space between channel and fixtures.  
Materials: 18 gauge (1.2).

P2602

MERCURY VAPOR FIXTURE HANGER

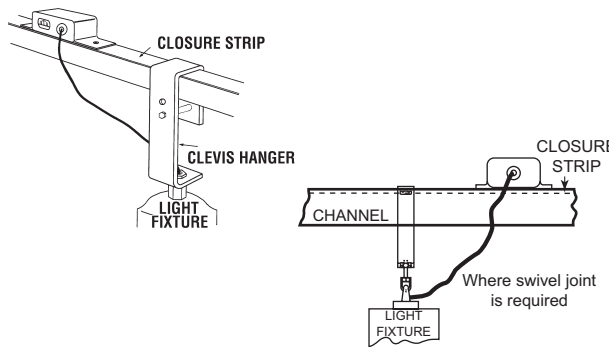
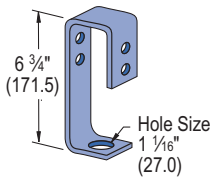

Use with 1 1/2" Channel  
Finish: Electro-galvanized  
Stock Size: 1/4"  
NOTE: Supports fixture in slot up or down system.

Wt/100 pcs: 154 Lbs (69.9 kg)

Part No.	Use w/Channel	"A" In (mm)	Wt/100 pcs Lbs (kg)
P2537	P1000		
	P1100	27/16 61.9	19 8.6
	P3000		
P5537	P5500	3 1/4 82.6	22 10.0

P2539, P3539, P5539

FLUORESCENT FIXTURE HANGERS

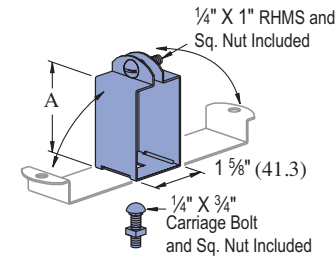

• Hanger provides 1/8" (3.2) space between channel and fixtures.  
Materials: 18 gauge (1.2).

Design Load  
120 Lbs (0.53 kN)

Part No.	Use w/Channel	"A" In (mm)	Wt/100 pcs Lbs (kg)
P2539	P1000	1 1/4 44.5	17 7.7
	P1100	1 1/2 38.1	15 6.8
P3539	P3000	1 1/2 38.1	15 6.8
P5539	P5500	2 5/16 65.1	18 8.2

P3922 THRU P3926

SPLICE FITTINGS

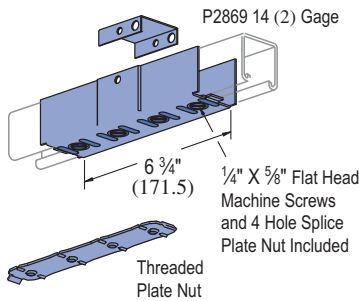

Assy. No.	Use W/ Channel	"A" In (mm)	Clevis No.	Back Clevis No.	Plate Nut No.	Wt/100 pcs Lbs (kg)
P3922	P1000	1 5/8 41.3	P2377	P2517	P2869	100 45.4
	P1100					
P3923	P3000	1 3/8 34.9	P3377	P2517	P2869	97 44.0
P3924	P4000	1 1/16 20.6	P5377	P2517	P2869	80 36.3
P3925	P5500	1 5/8 41.3	P2377	P5517	P2869	103 46.7
P3926	P5000	1 5/8 41.3	P2377	P5017	P2869	106 48.1

Material: 16 gauge (1.6).

P3521-50

END CONNECTORS FOR 1/2" CONDUIT

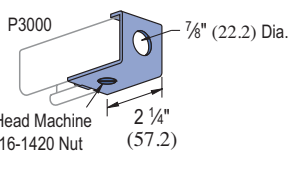

Material: 12 gauge (3).

Wt/100 pcs: 27 Lbs (12.2 kg)

P2521-50, P2521-75

END CONNECTORS FOR 1/2" & 3/4" CONDUIT



1/4" X 5/8" Flat Head Machine Screw and P3016-1420 Nut Included

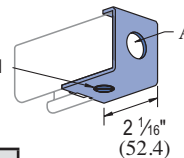

Part No.	Conduit Size In	Wt/100 pcs Lbs (kg)
P2521-50	1/2	27 12.2
P2521-75	3/4	26 11.8

Use with channels:  
P1000 and P1100.  
Material:  
12 gauge (3)

P5521-50, P5521-75

END CONNECTORS FOR 1/2" & 3/4" CONDUIT



1/4" X 5/8" Flat Head Machine Screw and P3016-1420 Nut Included

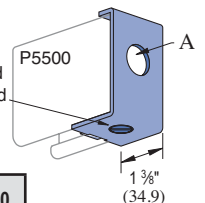

Part No.	Conduit Size In	Wt/100 pcs Lbs (kg)
P5521-50	1/2	27 12.2
P5521-75	3/4	26 11.8

Material:  
12 gauge (3).